

Manufactured by:

**HAPAM**

## Double-Break Disconnectors Type SSBIII



Visayan Electric Company Inc. (VECO) Naga 138 kV Switchyard

- HAPAM has more than 75 years of experience
- Durable and reliable design
- Over 30,000 HAPAM disconnectors and earthing switches are in service in more than 80 countries throughout the world
- Used by major utility companies in the Philippines
- Virtually maintenance free

pazifik  
power

[www.ppi.ph](http://www.ppi.ph)

## General

The horizontal double-break disconnecter consists of three poles. Each pole consists of a frame, two supporting insulators at each end and one rotating insulator at the center, on which the main blade is mounted.

## Frame

The frame is made of a square tube in which in the center the bearing housing and the turnable are installed.

The turnable is supported by two roller bearings. The bearing housing is sealed and filled up with grease, to ensure a long lifetime.

All steel parts of the disconnecter are hot dip galvanized.

## Insulators

The disconnecters can be equipped with insulators in accordance with IEC or ANSI specifications.

## Drive Mechanism

The Disconnecters and/or earthing switches can be single-pole or three-pole operated by means of a motor-operated drive mechanism or a manual-operated drive mechanism.

In case only one drive mechanism is used for three-pole operation, the poles are interconnected by means of adjustable coupling rods.

The drive mechanism also houses the auxiliary contacts for position indication.

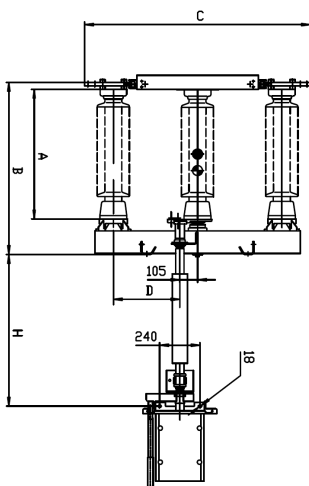

## Main Blade

The main blade consists of two fixed contacts, mounted on the supporting insulators, and a moving blade mounted on the rotating insulator. The main contacts are installed inside the main blade. They are made of copper, with a silver-plated surface.

Each contact finger is provided with stainless steel springs to ensure reliable contact pressure.

The contacts are self-cleansing, which makes the disconnecter suitable for installation in areas with severe climatic conditions.

Depending on the voltage rating, anticorona shields will be provided.

## Earthing Switch

HAPAM disconnecters may be equipped with earthing switches, which can be built on to the right hand side and/or to the left hand side.

The earthing switch consists of an aluminum tube, provided with silver-plated contacts at both ends.

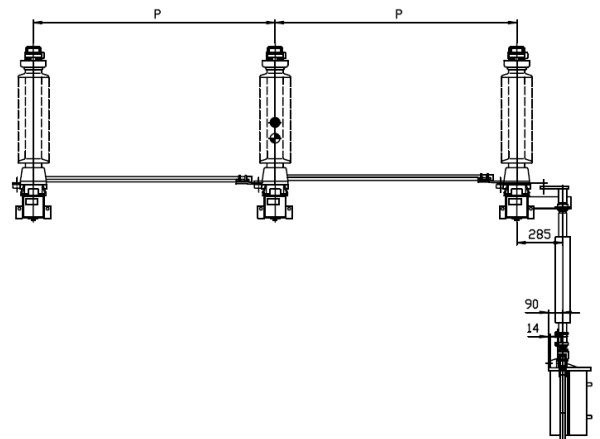
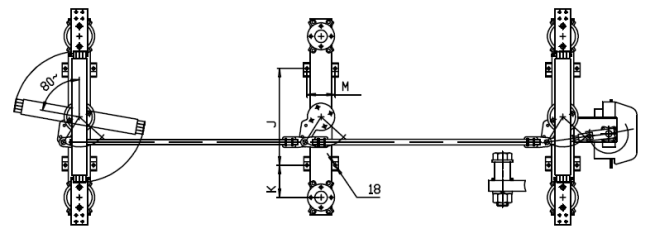

## Testing

The disconnectors and earthing switches are designed and tested in accordance with latest IEC specifications. HAPAM maintains a quality assurance system according to ISO 9001, certified by KEMA.

## Maintenance

The disconnectors and earthing switches supplied by HAPAM are designed so as to ensure that they are virtually maintenance free. However, to warrant a long and trouble-free service period we advise that a visual inspection of the contacts and bearing points be carried out at regular intervals.

## Installation

The disconnectors and earthing switches are pre-assembled and adjusted in our works as complete as possible.

The construction is designed so that all disconnectors can be installed and adjusted at site very easily, without the need of any special tools. HAPAM provides clear installation instructions and assembly drawings.

### Technical Data - SSBIII

Rated Voltage		72.5	123	145	245	550
Lightning Impulse						
Lightning Impulse Withstand Voltage						
-to earth	kV	325	550	650	1050	1550
-across the isolating distance	kV	375	630	750	1200	1550
						+315
<b>Power Frequency Withstand Voltage</b>						
-to earth	kV	140	230	275	460	620
-across the isolating distance	kV	160	265	315	530	800
<b>Switching Impulse Withstand Voltage</b>						
-to earth	kV	-	-	-	-	1175
-across the isolating distance	kV	-	-	-	-	900
						+450
<b>Current and Short Circuit Ratings</b>		<ul style="list-style-type: none"> <li>■ 1600 A - 80 kA peak - 32 kA/ 3 sec.</li> <li>■ 2000 A - 100 kA peak - 40 kA/ 3 sec.</li> <li>■ 3150 A - 125 kA peak - 50 kA/ 3sec.</li> <li>■ 4000 A - 160 kA peak - 63 kA/ 3 sec.</li> </ul>				

### Dimensions (mm) - SSBIII

Voltage (kV)	72.5	123	145	245	550
<b>A</b>	770	1220	1500	2300	4400
<b>B</b>	1195	1645	1925	2805	5085
<b>C</b>	900	1400	1650	2600	4400
<b>D</b>	250	700	825	1300	2200
<b>F</b>	485	750	875	1440	2450
<b>G</b>	1190	1985	1965	2740	5150
<b>J</b>	500	1000	1250	2000	3700
<b>K</b>	200	200	200	300	350
<b>L</b>	-	-	-	100	200
<b>M</b>	175	175	175	210	280
<b>P&amp;H</b>	defined by substation lay-out				

# TRANSMISSION EQUIPMENT

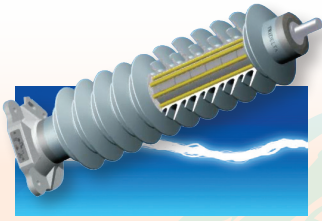

## Surge Arrester

Silicon arrester in cage design  
Substation Type Arrester Protection  
against atmospheric overloads  
rated up to 800kV



## Smart Navigator Fault Indicator with Communication

Designed and engineered for Smart Grid  
Distribution, Automation, Application



## Power Voltage Transformer

72,5 to 550 kV  
Unique design with an open magnetic  
core – ensuring ferroresonance  
immunity, rated output capacity of  
10-100kVA per phase



## Combined Instrument Transformers

Type VAU - 72,5 to 550 kV  
High-precision measurement accuracy  
and protection classes with superior  
transient response



## Medium Voltage Switchgears

Switchgear contributes to improving  
electrical distribution in Medium Voltage  
networks up to 36 kV with rated current  
up to 2,500 A



## High Voltage Disconnectors

Rated 69kV up to 800kV



## Liona

Automatic online PD detection and  
localization on XLPE cables

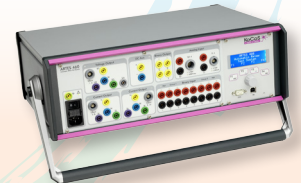

## Circuit Breaker Testing

Guaranteed high level of accuracy

## Efficient Electricity Solutions

PPI Pazifik Power, Inc. (PPI) is a company with more than twenty (20) years of successful operation in the Philippines.

Over the years, PPI has developed and actively supplied an extensive and full power line of products and services from the best manufacturers in Europe. Among its most sought top-of-the-line products are: Turnkey projects in the supply of substations with rated voltage of up to 230kV, electricity meters, meter test equipment, instrument transformers, power transformers, disconnectors, fault indicators, surge arresters, switchgears, oil testers, cable diagnostics, batteries, harmonic filters, and automation systems, among others.

PPI's commitment is to establish closer customer relationship, so us to understand it's customer's power solution requirements. More importantly, PPI's cutting edge is its high quality, durable and innovative power solution equipment coupled with its unparalleled delivery of reliable on-time serve performance by its seasoned professional Electrical Engineers.



### MAKATI HEAD OFFICE

4/F and 6/F, South Park Plaza, Santiago Street  
Paseo de Magallanes Commercial Center  
1232 Makati City, Metro Manila, Philippines

Tel.: +63 2 511 88 88 | Fax: +63 2 836 43 23  
E-mail: info@ppi.ph | Website: www.ppi.ph  
Facebook: www.facebook.com/PazifikPowerInc

### CEBU BRANCH

Unit 3 ASY Bldg. A.C. Cortes Ave.  
Mandaue City, Cebu, Philippines  
Telefax: +63 32 520 55 23

