

Manufactured by:



Fault - Circuit Indicator for Overhead Lines Navigator - LM



- Fault detection; momentary versus permanent
- LED indication with 360 degrees of visibility
- Double-flashing mode upon detection of a second fault
- Battery status indication
- Reset depending on type: manual, current restoration, timed, on restoration of voltage
- Mounting can be performed while overhead line is energised
- NAVIGATOR-LM HV: permissible voltage ≤ 161 kV

Description

The NAVIGATOR short-circuit indicator is an electronic device which is designed for medium voltage utility overhead lines.

The indicator is provided with a self-adjusting load-dependent control of the trip current level. This function allows the indicator to continuously sample the load current on overhead lines and electronically set a corresponding trip value for fault detection as a function of the load current. The maximum load current sampled by the indicator, is kept in a memory for a period of at least 72 hours. Thus, the indicator is most favourably adapted to the network to be monitored, even if low load is currently present.

The indicator is provided with a built-in battery control. When the battery capacity decreases from a total indicating time of 500 hours to a residual time of 50 hours, the yellow LED of the display starts flashing for a period of 6 months.

20 1995-2015
Years
efficient electricity solutions

pazifik
power

www.ppi.ph

Function

The NAVIGATOR-LM differentiates between two subsequent short-circuit detections. Upon the detection of a first short-circuit, the LED indicator light starts flashing at equal rates. The detection of a second short-circuit (e. g. after ARC) switches the LED to double flashing mode.

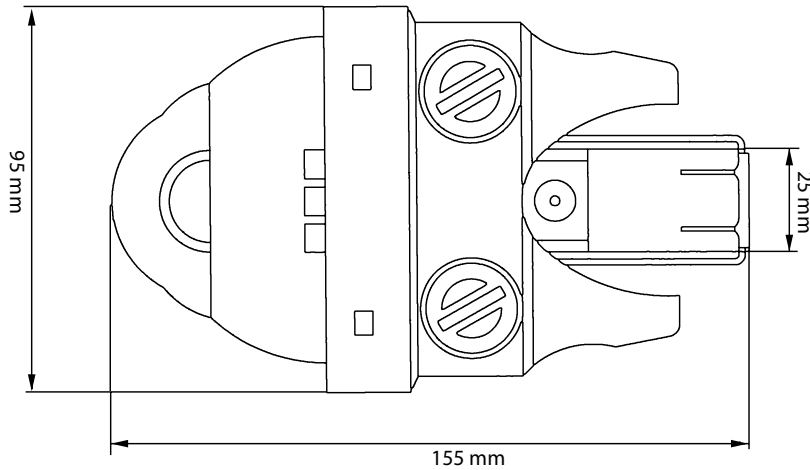

Time / current characteristic Navigator LM

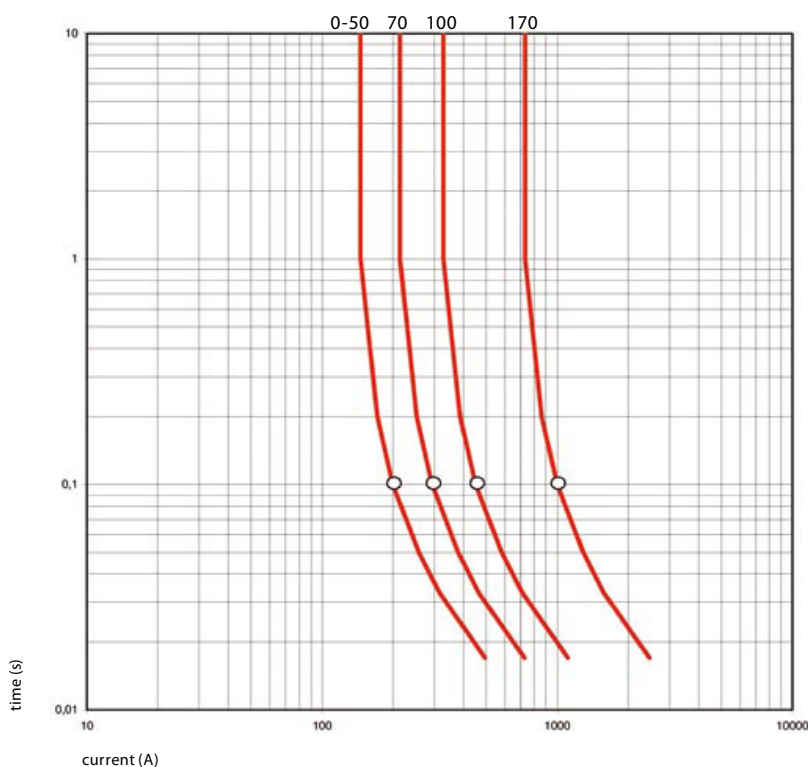

Load current [A]	0 - 50	70	100	170
Trip current [A] / 100 ms	200	294	450	1000



Special features of different types

NAVIGATOR Version A

Faults are indicated by means of 6 high-intensity LEDs. The indication is reset automatically on restoration of current or after expiry of a pre-set time, or can be reset manually, whichever criterion occurs first.

NAVIGATOR Version B

Faults are indicated by 6 high-intensity LEDs. The indication is reset automatically after expiry of a pre-set time, or manually.

NAVIGATOR Version C

Faults are indicated by means of 4 red LEDs and 2 yellow high-intensity LEDs. The red LED indicator lights are reset automatically on restoration of current, after expiry of a pre-set time, or manually. The yellow LED indicator lights are reset automatically after expiry of a pre-set time, or manually.

NAVIGATOR Version E

The indicator samples both the line current and voltage on the line. The device is tripped only if the line has been under voltage for at least 60 seconds. Automatic reset after 60 seconds upon restoration of voltage, after passage of a pre-set time, or manual reset. Its design blocks high inrush currents for indication, even upon reclosure. Both the overbuilt and underbuilt conditions shall be avoided!

Technical Data	NAVIGATOR-LM / LM HV			
	Version A	Version B	Version C	Version E
Trip current range	≥200 A / 100 ms, load-dependent self-adjustment (see current/time characteristic)			
Accuracy	±10 % at 20 °C			
Self-adjustment	≥50 A load current			
Trip factor	4 – 6 x load current (see current/time characteristic)			
Adjustment delay	≥50 s load current flow time			
Holding time of self-adjustment	72 h			
Indicators (short-circuit /earth fault)	<ul style="list-style-type: none"> • 4 red LEDs (>5,000 mcd or 7,000 mLm per piece) • 2 yellow LEDs 			
Visibility	>50 m / day, >150 m / night / 360 degrees of visibility			
Flash rate	30 flashes per minute, total indication time >500 h			
Reset	<ul style="list-style-type: none"> • Manual reset by mean of a permanent magnet • Automatic time reset: 4 h ±10 % (2 or 8 h) 			
	Current restoration >3 A load current	—	Current restoration >3 A load current	—
	—	—	—	Voltage restoration, line voltage ≥5 kV
Power supply	Lithium cells, replaceable, shelf life ≥20 years			
Battery check	1 yellow LED, flash rate: 6 per minute, 0.5 years			
Max. permissible voltage	<ul style="list-style-type: none"> • NAVIGATOR-LM: ≤46 kV / 50 Hz or 60 Hz • NAVIGATOR-LM HV: ≤161 kV / 50 Hz or 60 Hz 			
Withstand current	<ul style="list-style-type: none"> • NAVIGATOR-LM: 25 kA / 200 ms • NAVIGATOR-LM HV: 40 kA / 1 s 			
Cable diameter range	<ul style="list-style-type: none"> • NAVIGATOR-LM: 8 – 29 mm • NAVIGATOR-LM HV: 13 – 36 mm 			
Influence	No influence by vicinal power lines with a horizontal distance of at least 250 mm from the indicator			
Housing	UV-resistant polycarbonate / polyamide, IP68 Clamping mechanism: stainless steel			
Temperature range	-30 to +70 °C (ANSI Test -40 to +85 °C)			

Short-Circuit Indicator for Overhead Lines Navigator-LM Radio

- Radio Transmitter
- Control LED

The Navigator-LM Radio Short-Circuit Indicator for overhead lines is used for the detection and remote indication of short-circuits in medium-voltage overhead lines.

The Navigator-LM Radio works always in combination with a radio receiver which is mounted on the overhead line pole. Once a short-circuit has been detected, the Navigator emits a signal to the radio receiver via an incorporated transmitter. The radio signals are evaluated by the receiver and the resultant status including battery control is provided to the output contacts. Four different code configurations – A, B, C and D – can be adjusted. Permanent or momentary contact, battery monitoring as well as coding of the group message can be adjusted on the receiver.

Technical Data	
Trip Current	100 A / 100 ms (without load tracking)
Accuracy	±10% @ 20°C, ±20% @ -20°C to +70°C
Load tracking	Load ≥30 A
Trip factor / trip delay	4 times the load / delay ≥ 50 s, level memory ≥72 h
Current resetting / Time resetting	≈ 3 A / 4 h ±20%
Indication / flashing frequency	Red LED flashes every 2 s on excitation
Battery control	Yellow LED flashes every 10 s upon reaching 500 h active time
Function test	By means of a magnet that must be applied along the SET / RESET point
Total indicating time (flashing time)	> 700 hours
Power supply	2 replaceable lithium battery packs, approx. 15 years shelf life
High-voltage / frequency	≤ 46 kV / 50 Hz
Current withstand / Immunity against external field influence	25 kA effective @ 200 ms / 22 cm @ 10 kA
Cable diameter	8 – 29 mm
Temperature range	-30°C to +75°C
Housing / installation	UV-stable polycarbonate / hot-stick application
Weight	480 g
Clamping mechanism	Stainless steel
Radio transmission	Integrated antenna
Frequency / capacity / Modulation / transmission	869,850 MHz ±25 kHz / 1 mW / FM/ periodically every 1 to 1.6 s for 100 ms
Transmission range / Compatibility	>30 m / EN 300 220-3, EN 301489-3 (EMV)
Coding	A, B, C and D, each with excitation and battery control

Associated facility	
28-7000-007	Radio Receiver with 6 relay outputs

Efficient Electricity Solutions

PPI is a company with more than twenty (20) years of successful operation in the Philippines.

Over the years, it has developed and actively supplied an extensive and full power line of products and services from the best manufacturers in Europe. Among its most sought top-of-the-line products are: Turnkey projects in the supply of substations with rated voltage of up to 230kV, electricity meters, meter test equipment, instrument transformers, power transformers, disconnectors, fault indicators, surge arresters, switchgears, oil testers, cable diagnostics, batteries, harmonic filters, and automation systems, among others.

Our commitment to establish closer customer relationships and to further improve your business operation make us understand your power solution requirements. PPI's seasoned professional Electrical Engineers deliver the unique support tailored-fit for each customer needs. The company's cutting edge is its high quality, durable, and innovative power infrastructure equipment and an unparalleled delivery of reliable on-time service performance.

 <p>www.ppi.ph</p>	<p>MAKATI HEAD OFFICE</p> <p>4/F and 6/F, South Park Plaza, Santiago Street Paseo de Magallanes Commercial Center 1232 Makati City, Metro Manila, Philippines</p>	<p>Tel.: +63 2 511 88 88 Fax: +63 2 836 43 23 E-mail: info@ppi.ph Website: www.ppi.ph Facebook: www.facebook.com/PazifikPowerInc</p>	<p>CEBU BRANCH</p> <p>Unit 3 ASY Bldg. A.C. Cortes Ave. Mandaue City, Cebu, Philippines Telefax: +63 32 520 55 23</p>	 
--	--	--	--	--