

Manufactured by:



Cashpower Gemini HMI

Prepayment Electricity Meters / Residential



Cashpower Gemini HMI is part of the Gemini family of prepayment meters and is a single-phase, keypad-based, stand-alone or split prepayment electricity meter in a British Standard housing. If used as a split prepayment meter, it comprises two parts, namely the meter and the customer interface unit.



pazifik
power

www.ppi.ph

Overview

This specification sheet is for the Gemini HMI prepayment meter utilising version 11 meter firmware.

The Cashpower Gemini HMI is a single-phase, keypad-based, stand-alone or split prepayment electricity meter in a British Standard housing.

The Gemini HMI can be used as a stand-alone prepayment meter, typically installed inside the household, but can also be used as a split prepayment meter by simply connecting the customer interface unit, which will then be the customer's only interface with the meter.

When used as a split metering solution, the meter is usually installed in a secure, locked enclosure, typically a pavement kiosk or pole-mounted equivalent.

The customer interface unit is usually installed in a convenient location in the consumer's home - remote from the meter and is connected to the meter with a pair of communications wires.

Features

- Split prepayment meter, significantly reducing the possibility of fraud and bypassing
- Compact meter design with British Standard layout
- Easy to install and ideal for new reticulation as well as retrofitting of credit meters with BS footprints
- Proven Cashpower keypad technology
- Programmable operating modes:
 - o Prepayment
 - o Credit metering
 - o Energy Limiting Mode
- Galvanically isolated communication to customer interface unit for consumer safety
- Tamper detection features
- Significant Reverse Energy (SRE) detection
- Programmable software power limit
- Commissioning / decommissioning feature
- Language independent user interface
- Large LCD and keypad on the meter
- Improved sealing against ingress of insects
- High surge withstand capability for areas prone to lightning or other line surges
- SANS 1524-1 and IEC 62055-31 compliant
- STS Compliant

Principle of Operation: Split metering

The split meter solution consists of two parts namely, the customer interface unit and the meter.

The customer interface unit is the customer's only interface with the meter, and is a compact unit with a user-friendly keypad and display. It is usually installed in a convenient location in the consumer's home - remote from the meter, and is connected to the meter with a pair of communications wires up a distance of 130 metres.

The meter contains all critical metering, number decryption and load control functionality. It operates independently and is immune to any form of tampering on the Customer Interface Unit.

The meter is usually installed in a secure, locked enclosure, typically a pavement kiosk or pole-mounted equivalent. It is outside the customer's home to facilitate easy inspection by the utility at any time and to reduce the opportunity of fraud and tampering. The meter is fitted with a LCD display and keypad, which allows the utility to view important meter parameters without the need for an interrogation tool.

Principle of Operation: Meter modes

The Cashpower Gemini HMI meter provides utilities with the utmost flexibility in terms of being able to adapt to a range of different consumer profiles. Three, utility-programmable modes of operation are available and it is possible to switch between modes as required:

- Prepayment Mode
- Credit Mode
- Energy Limiting Mode

Prepayment Mode

In Prepayment metering mode, it functions as a normal prepayment meter. Credit tokens are purchased and entered into the meter via the customer interface unit keypad. On expiry of credit, the load is disconnected and will only be re-connected when a valid credit token, purchased by the consumer, is entered.

Credit Mode

In Credit metering mode, it functions as a conventional credit meter. Power is continuously supplied to the consumer and total kWh used is continuously measured and recorded. The meter must be read by the utility at regular intervals and the consumer billed accordingly.

Energy Limiting Mode

This mode allows utilities to distribute a fixed, monthly allocation of energy to consumers. It encourages the rational use of energy without severely inconveniencing the consumer. Operation is as follows:

Assume that a monthly energy allowance of 150kWh has been allocated to a consumer. The meter allocates this energy in regular, equal portions, over the thirty-day period i.e. by incrementing the kWh credit level with a value of 0.00087kWh every 15 seconds.

Assuming that the consumer draws no power at all, the credit level will continue to increase. However, as soon as energy starts to be used, the credit level is proportionately decremented. If the rate at which energy is being used is less than the rate at which it is being incremented, the credit level will slowly continue to increase. If the rate at which energy is being used is greater than the rate at which it is being incremented, the credit level will slowly decrease.

It is in the consumer's interest to ensure that electricity is not wasted and that unnecessary appliances are turned off. By conserving energy, it will be possible to use it at a high rate for periods when required.

In the event of the consumer exceeding the allocated allowance (credit level reduced to zero), the load is disconnected. However, the next allocation of credit will be available within a very short period of time (15 secs) and the supply of electricity restored. Providing the consumer takes immediate steps to disconnect unnecessary appliances, it will be possible to have at least basic services available e.g. lighting. With a 150kWh monthly allocation of energy, it will be possible to maintain a continuous load of 200W whilst still maintaining a positive credit balance.

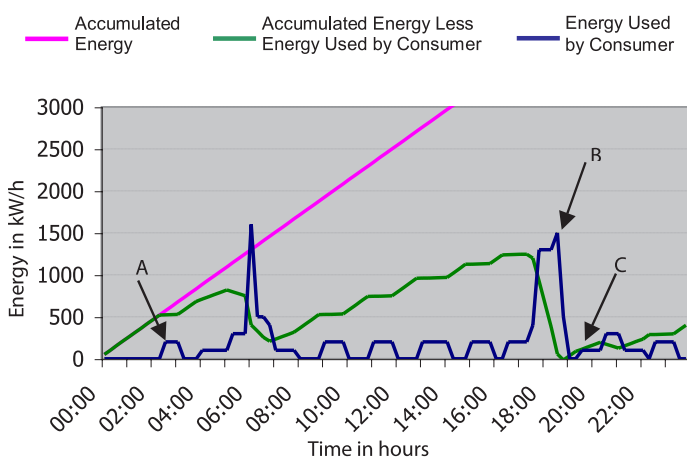

Figure 1: Graphical Representation of Typical Operation

- A) Consumer starts using energy
- B) Consumer depletes accumulated energy and load is disconnected
- C) Consumer starts using energy again after load is re-connected

User-friendly customer interface

User interaction with the meter and access to meter information (such as a low credit warning, energy consumption, and load contactor status) is available using the meter's or the customer interface's keypad and LCD display. The meter and customer interface make use of clear, language-independent icons.

In addition, various audible tones are sounded in the customer interface unit under different conditions (e.g. Low Credit Alarm).

The meter is fitted with a keypad and LCD display. This allows the utility staff to inspect and update various parameters of the meter in the remote kiosk without having to gain access to the consumer's house to access the customer interface unit.

Interrogation port

More detailed information and programming is achieved via the standard interrogation port at the rear of the meter.

Optical interface

As a standard feature, the Gemini HMI family offers an IEC 62056-21 compliant optical communications port. This allows the utility to access a variety of information stored inside the meter.

Tamper detection

The split configuration of Gemini HMI meter significantly reduces the risk of tampering. The meter is installed in a remote, secure location and is mechanically sealed against tampering through the use of a factory-sealed screw plug on the rear panel, and a utility-sealed wire seal on the front of the meter. The use of these mechanical seals ensures that there are visible signs of tampering if unauthorised entry to the system is attempted.

In addition, the units are equipped with a terminal cover tamper sensor that will automatically disconnect the power to the load in the event of tampering.

The meter also has a feature allowing detection of Significant Reverse Energy (SRE). If the line and load wires are swapped during installation, the meter will continue to operate and decrement credit but can be factory programmed to tamper and disconnect the load should SRE be detected.

Surge protection

The Gemini HMI meter has the option of being supplied with a built in surge arrester that is capable of sustaining up to 30kA during transients.

Communication line protection

The communications interface can withstand voltage surges of 6kV, however it is recommended that one of the communication lines be earthed at the meter for additional protection.

Cashpower Gemini HMI Technical Specifications

General Information

Meter Format

Single-Phase, 2-wire, direct connected prepayment meter

Compatible network(s)

Single-Phase, 2-wire, earthed neutral¹

Operation

General

Prepayment, Credit and Energy Limiting Modes

Credit entry mechanism

Keypad; encrypted numbers

Encryption algorithms

STS Compliant²

Applicable specifications

NRS009 - 1; NRS009 - 6 - 6; NRS009 - 6 - 7;³

Electrical Ratings

Nominal Voltage (U_n) - Rated Voltage

230 Volts AC rms (other voltages available on request)

Nominal frequency

60Hz

Operating voltage range

80% to 120% of U_n (184V – 276V)

Maximum continuous current (I_{max})

80 Amps (factory and field programmable to lower power limits)

Burden

Voltage circuit <1.8W / <10VA @ 230V

Current circuit <2.5 VA @ Base Reference Current (I_b)

Protective class (according to IEC 62052-11)

Class II (double insulated)

Metrological Performance

Measurement direction

Forward and reverse power detection and metering⁴
(Credit is decremented in both directions)

Meter constant (LED flash rate)

1000 impulses / kWh

Basic reference current (I_b)

10A⁵

Accurate metering range

0.05 I_b to 1.2 I_{max} ⁶

Starting current

$\leq 0.005 I_b$ (For Class 2)

Power threshold

6.5W (approx 28mA @ 230V and $\cos(\Phi) = 1$)⁷

Accuracy class index

Class 1 and Class 2 meters available

¹ May be compatible with other network types as well – Consult Landis+Gyr

² STS = Standard Transfer Specification (Industry Standard)

³ NRS = National Rationalised Specification (South Africa)

⁴ Will accurately meter energy if Line and Load connections are reversed. Can also be configured to tamper on reverse energy detection.

⁵ Other Base Currents available on request.

⁶ The metering is accurate within the limits specified by IEC62053 -21. Should a meter momentarily be operated outside its specified maximum current rating it will meter accurately up to 1.2 I_{max} .

⁷ The Power Threshold represents the minimum load power that the meter will register. This value is programmable, with the recommended level for a base 10A meter shown.

Maximum error

Class 1
 $< \pm 1\%$ over range $0.1 I_b$ to I_{max} ; $0.5 \leq \cos(\Phi) \leq 1.0$
(lead or lag)⁸

Class 2
 $< \pm 2\%$ over range $0.1 I_b$ to I_{max} ; $0.5 \leq \cos(\Phi) \leq 1.0$
(lead or lag)

Disconnection Device

Type

Single Pole latching contactor 100A

Insulation, Overvoltage and Surge Protection

Insulation System Classification

Protective Class II (according to IEC 61036)

Insulation Level

4kV rms for 1 minute

Overvoltage withstand

440VAC for 48 hours⁹
600VDC for 1 minute¹⁰

Surge Immunity – Voltage impulse withstand

Differential
In excess of 6kV, 1.2/50µs, with 2Ω source impedance (according to SABS 1524 -1)

Surge Immunity – Current impulse withstand

Service rating
5 kA 8/20µs (with optional surge arrester populated)

Withstand rating
30 kA, 4/10µs (with optional surge arrester populated)

Specification compliance
SA NS 1524 -1, IEC 62052 -11

Electromagnetic compatibility (EMC)

Electrostatic discharge 15 kV air discharge
Immunity to HF fields

80 MHz to 2 GHz @ 10V/m with load, 80MHz to 2GHz @ 30V/m no load

Immunity to fast transient bursts 4 kV

Radio interference
Complies with requirements for CISPR 22

Specification compliance
IEC 61000 -4 -2; IEC 61000 -4 -3;
IEC 61000 -4 -4; IEC 61000 -4 -6 CISPR 22

Communication Circuitry

Type

Galvanically Isolated, Non -Polarised, 2 -wire, half -duplex. Meter is independent of CIU function

Rated Impulse Voltage

Peak Voltage 6kV (1,2/50µS) waveform (according to IEC 62052 -11 Protective Class II)

Insulation Properties

4kVrms (1 minute) (according to IEC 62052 -11 Protective Class II)

Communication Distance

Up to 130 metres, with a maximum total loop resistance of 40Ω

Main Enclosure

Type

Layout according to BS5685 footprint

Mounting

Two mounting screws bottom (spacing according to BS5685). Top mounting bracket available as an option

Rating

IP54 (IEC60529)¹¹

⁸ IEC 62053 -21: $0.8 \leq \cos(\Phi) \leq 1.0$ Leading, $0.5 \leq \cos(\Phi) \leq 1.0$ Lagging

⁹ This higher specification (440V as opposed to 400V) has not yet formed part of the official specification

¹⁰ This higher end test is not a requirement of IEC 62052

¹¹ Only IP51 rating is required by IEC 62052 -11 for indoor meters

Material

UV Stable Polycarbonate/ABS blend with flame-retardant

Resistance to heat and fire
Complies with 960°C¹² glow -wire (IEC 60695 -2-1)

Resistance to spread of fire
UL94-V0 rated @1.5mm.
No toxic gases emitted: 'Green Material'¹³

Dimensions

127.6mm(H) x 122mm(W) x 68mm(D) with short terminal cover

Mass

510 g

Terminals

Layout

According to BS5685

Mains Terminals

Type Double screw (M6), moving-cage terminal

Material Mild steel, yellow passivated

Maximum Cable Size 25mm²

Terminal Block Material

UV Stable Polycarbonate with flame-retardant

Resistance to heat and fire
Complies with 960°C¹⁴ glow -wire (IEC 60695 -2-1)

Resistance to spread of fire
UL94 -V0 rated @1.5mm.

No toxic gases emitted: 'Green Material'¹⁵

Customer Interface Unit Terminals

Type Single screw cage terminal (moving screw)

Maximum cable size 2.5mm²

Sealing

Type

Meter enclosure Factory sealed with screw-sealing plugs

¹² Only 650°C called for by standard industry specification

¹³ No V-rating or 'Green' material called for by industry specifications

¹⁴ Only 650°C called for by standard industry specification

¹⁵ No V-rating or 'Green' material called for by industry specifications

Terminal cover Utility sealed with wire and crimped ferrule

Operating Environment

Area of application

Indoor meter (according to IEC62052-11)

Operating temperature range

-10°C (+14°F) to +55°C (+131°F)

Storage temperature range

-25°C (-13°F) to +70°C (+158°F)

Relative humidity

Maximum ≤95%; Annual mean 75%

Man-Machine Interface

Rate of consumption indicator

Visible LED, 1000 pulses/kWh

Liquid Crystal Display (LCD)

Size 9cm² (45mm (W) x 20mm (H)),
8 digits + 11 icons
Digit height: 9.3 mm

Icon information
Happy face, Sad face, Alert, Breaker status,
Info, kWh, 4-segment credit wedge

Numeric information
Display of various meter information
such as credit levels, number entry, etc. Additional
meter parameters are accessible via the "Information" key

Keypad

12 -key, international standard layout including
"Information" and "Backspace" keys

Buzzer

Audio feedback on key-press.

External Interfaces

Standard Interrogation Port

8-pin VTC interface according to ESKOM
DISSCAA9

Optical Communications Port

According to IEC 62056-21

Proprietary Interrogation Port

Data interface for Cashpower Powerscope

Specifications Compliance & Approvals

IEC

IEC 62055-31

SABS

SANS 1524-1

Cashpower Customer Interface Unit

Electrical

Type

Isolated, non-polarised, 2-wire, half-duplex, 12Vdc from meter

Operating Range (Communication)

Up to 130 metres, with a maximum total loop resistance of 40Ω

Operating Environment

Operating Temperature Range

-10°C (+14°F) to +55°C (+131°F)

Storage Temperature Range

-25°C (+12°F) to +70°C (+158°F)

Relative Humidity (IEC 6 1036)

Maximum ≤95%; Annual mean 75% SABS

Enclosure

Type

Slimline, wall mounted

Rating

IP 51

Material

ABS

Dimensions

77.4mm(H) x 132.3mm(W) x 29mm(D)

Weight

100 g

Terminals

Type

2-way screw terminal

Maximum cable size

2.5mm²

ESKOM – Prepayment meters

ESKOM DISSCAA9

BS

BS 5685: 1979

Sealing

Enclosure

Factory Sealed, no user serviceable parts

Man-Machine Interface

Type

Language-independent

Components

Pictographic/Numeric LCD display, keypad, LED rate of consumption indicator, audio feedback

Liquid Crystal Display (LCD)

Size

9cm² (45mm (W) x 20mm (H)),
8 digits + 11 icons
Digit height: 9.3 mm

Icon information

Happy face, Sad face, Alert, Breaker status, Info, kWh, 4-segment credit wedge

Numeric information

Display of various meter information such as credit levels, number entry, etc.

Man-Machine Interface

Keypad

12 -key, international standard layout including "Information" and "Backspace" keys

Buzzer

Audio feedback on key press, encrypted number Accept and Reject melodies, Low-credit alarms as a factory-programmable option

Light Emitting Diode (LED)

Rate of consumption indicator (Pulse rate proportional to current rate of consumption)

Diagnostic Information

Me ter parameters accessible via the "Information" key

Cashpower Gemini HMI: Dimensions

METER DIMENSIONS - SHORT COVER

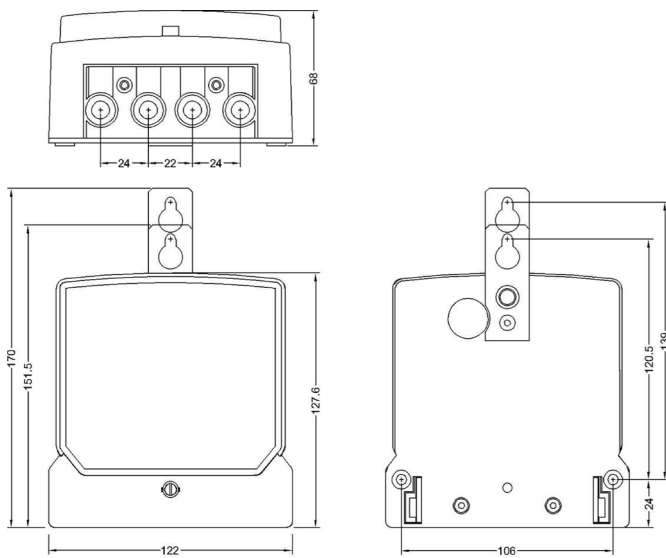

METER DIMENSIONS – LONG COVER

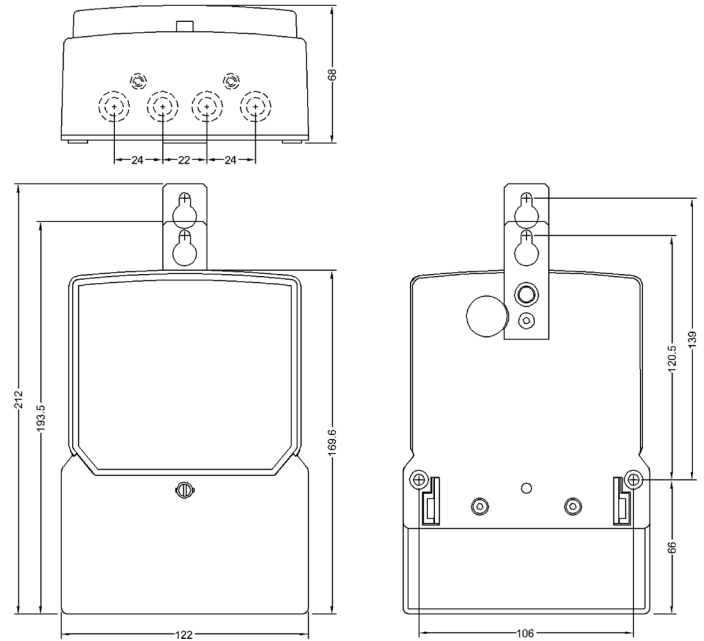

Cashpower Customer Interface Unit: Dimensions

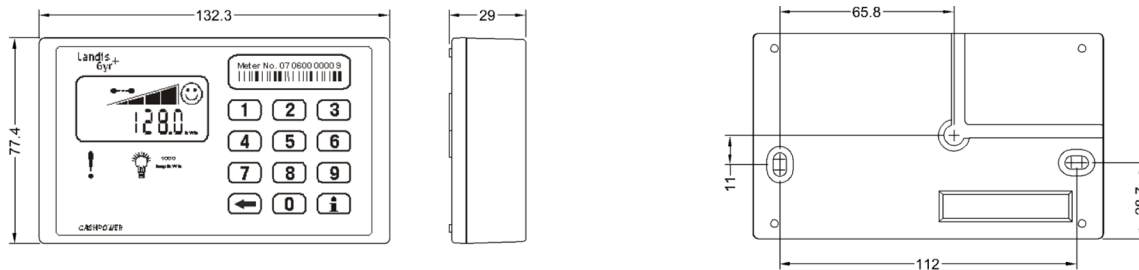

Efficient Electricity Solutions

PPI is a company with more than twenty (20) years of successful operation in the Philippines.

Over the years, it has developed and actively supplied an extensive and full power line of products and services from the best manufacturers in Europe. Among its most sought top of the line products are: Turnkey projects in the supply of substations with rated voltage of up to 230kV, electricity meters, meter test equipment, instrument transformers, power transformers, disconnectors, fault indicators, surge arresters, switchgears, oil testers, cable diagnostics, batteries, harmonic filters, and automation systems, among others.

Our commitment to establish closer customer relationships make us understand your business needs and power solution requirement.



www.ppi.ph

MAKATI HEAD OFFICE
 4/F and 6/F, South Park Plaza, Santiago Street
 Paseo de Magallanes Commercial Center
 1232 Makati City, Metro Manila, Philippines

CEBU BRANCH
 Unit 3 ASY Bldg. A.C. Cortes Ave.
 Mandaue City, Cebu, Philippines

Tel.: +63 2 511 88 88 | Fax: +63 2 836 43 23
 E-mail: info@ppi.ph | Website: www.ppi.ph
 Facebook: www.facebook.com/PazifikPowerInc

