

BT-A1-VA/1

Manufactured by:



TRIDELTA Überspannungsableiter GmbH

# VARISIL™ HE Distribution Surge Arresters



**With 50 years of experience in surge protection, TRIDELTA provides products suitable to the user's expectations.**

**Overvoltage protection is of key importance for utilities to improve their networks' quality and reliability.**

**Appropriate surge protection increases the quality of power supply and minimizes system outage costs.**

## **THE RIGHT SURGE ARRESTER AT THE RIGHT PLACE!**

Our VARISIL™ HE is of polymer housed gapless metal oxide type dedicated to overvoltage protection of Distribution networks.

The metal oxide varistor blocks are manufactured by ourselves using our own formulas and processes.

These blocks are mechanically bounded in a fiberglass reinforced epoxy resin, encapsulated in a silicone rubber housing providing outstanding insulation performance and low losses.

Our VARISIL™ HE surge arrester fulfils all requirements of IEC60099-4 (10kA/ Line Discharge Class 1) and ANSI/IEEE C62.11(Distribution Heavy Duty) latest editions.

pazifik  
power

[www.ppi.ph](http://www.ppi.ph)

# VARISIL™ HE

The VARISIL™ HE is available with different options and accessories.

## NO OPTION

The surge arrester is supplied with bolts, washers and clamp for connection.

## S3D2 OPTION

The surge arrester is supplied with a ground lead disconnecter and an insulating bracket. This option is recommended for improved continuity of service.

## IF OPTION

The surge arrester is supplied with an electronic fault indicator using a red flag for easy visualization.

## ACCESSORIES

- Metal bracket for horizontal or vertical mounting,
- Ground lead,
- Pedestal (insulated or not).

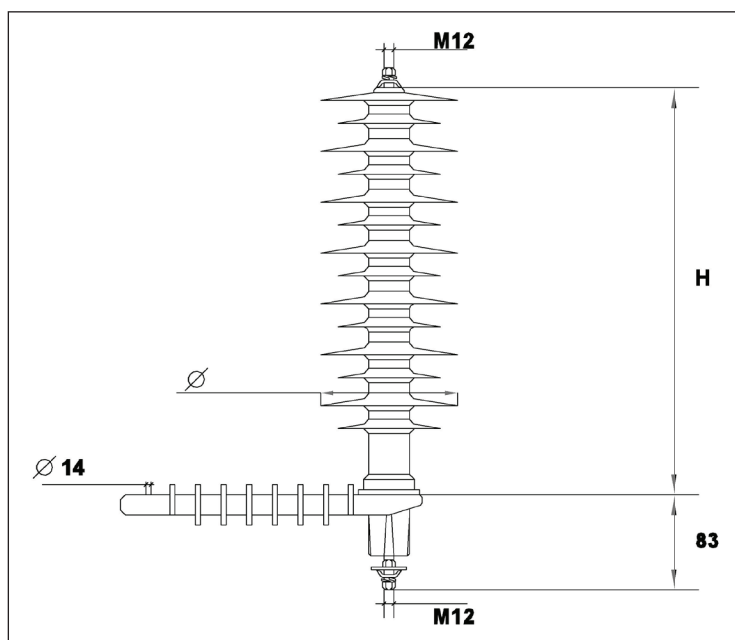

(\*) : for higher mechanical performance, refer to our HE-S or HI products

Rated Voltage (Ur)	5 to 36 kV rms
Nominal discharge current (In)	10 kA with 8/20 waveshape
Line discharge class	1
High current impulse withstand	100 kA with 4/10 waveshape
Long duration current impulse withstand	300 A with 2000µs waveshape
Energy absorption capability (with 4/10 waveshape)	4.8 kJ/kV of Uc
Maximum permissible static service load	10 daN.m (*)
Short circuit current withstand	20 kA / 0.2s - 600 A / 1s

Model	Unit	HE 05	HE 06	HE 09	HE 10	HE 12	HE 15	HE 18	HE 21	HE 24	HE 27	HE 30	HE 33	HE 36
Rated voltage Ur	kV rms	5	6	9	10	12	15	18	21	24	27	30	33	36
Continuous operating voltage Uc	kV rms	4.25	5.1	7.65	8.4	10.2	12.7	15.3	17.5	20.0	22.5	25.0	27.5	30.0
Maximum residual voltage	kV peak													
- at 5kA 8/20		14.3	15.4	26.4	27.5	30.8	40.7	46.2	56.1	61.2	72.2	76.2	87.2	91.7
- at 10kA 8/20		15.2	16.4	28.1	29.3	32.8	43.3	49.1	59.7	65.1	76.8	81.1	92.8	97.5
- at 20kA 8/20		16.8	18.1	31.1	32.4	36.2	47.8	54.3	66.0	71.9	84.9	89.6	102.5	107.5
Switching residual voltage at 500A - 30/80	kV peak	12.1	13.0	22.3	23.3	26.1	34.4	39.0	47.5	51.8	61.1	64.5	73.8	77.5
Steep current impulse residual voltage at 10kA - 1/2.5	kV peak	16.4	17.7	30.3	31.6	35.4	46.8	53.0	64.5	70.3	82.9	87.6	100.2	105.3
Lightning impulse withstand level of housing	kV 1.2/50	95			110			125			170			
Creepage distance	mm	480			650			800			1200			
Dimensions H	mm	165			205			245			325			
Ø	mm	104			109			114						
Weight (S3D2 option)	kg	1.3	1.3	1.5	1.5	1.6	2.0	2.1	2.5	2.6	3.1	3.2	3.4	3.5